

# Art. 01 05

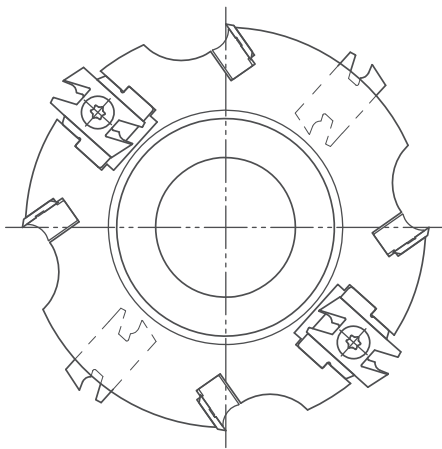

**TESTA A PIALLARE AD ALTO RENDIMENTO  
CON LEVASPIGOLI REGISTRABILI**

**HIGH EFFICIENCY PLANER HEADS,  
WITH ADJUSTABLE INSERTS**

**PO DE RABOTAGE A HAUT RENDEMENT AVEC BRISE-  
ARETES RÉGLABLES**

**HOCHLEISTUNGS-HOBELKÖPFE,  
VERSTELLBAR**

**CABEZALES PARA CEPILLAR DE ALTO RENDIMIENTO  
CON PORTA INSERTOS REGISTRABLES**

**ВЫСОКОЭФФЕКТИВНЫЕ СТРОГАЛЬНЫЕ ГОЛОВКИ С  
РЕГУЛИРУЕМЫМИ ФАСОЧНЫМИ НОЖАМИ**

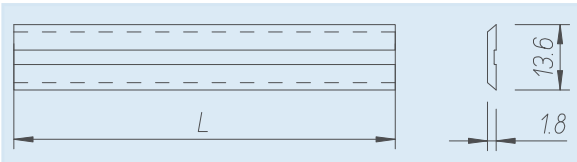
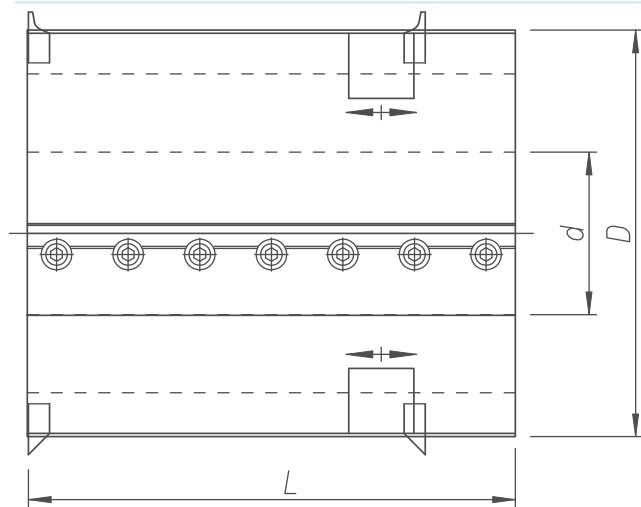

### Ricambi-Spare Parts

Descrizione- Description	Dimensione- Dimension	Codice-Code
Coltello-Knive (Lx13,6x1,8)	130	I93.130
	190	I93.190
	230	I93.230
Tassello-Wedge	130	I93.130/T
	190	I93.190/T
	230	I93.230/T
Vite-Screw D=100	M7x18	V13.7/18CE
Vite-Screw D>100	M7x24	V13.7/24,6CE
Vite-Screw	M6x14,5	V14.6/14,5CT
Vite-Screw	M8x16	V21.8/16CEPC
Sincron Dx-RH	-	I41.50D
Sincron Sx-LH	-	I41.50S

Cod.	D	L	d	Z	RPM max
100 130 00	100	130	30→40	3	10500
100 190 00	100	190	30→40	3	10500
100 230 00	100	230	30→40	3	10500
125 130 00	125	130	30→50	4	9100
125 190 00	125	190	30→50	4	9100
125 230 00	125	230	30→50	4	9100

### Inserti a scelta - Insert to choose

Descrizione- Description	Dimensione- Dimension	Codice-Code Dx-RH	Codice-Code Sx-LH
Raggiatori- RADIUSING	R 2,5	I40.CE25D615	I40.CE25S615
	R 3	I40.CE30D615	I40.CE30S615
	R 3,5	I40.CE35D615	I40.CE35S615
	R 4	I40.CE40D615	I40.CE40S615
Spigolatore- CHAMFERING	45°	I40.CE45D645	I40.CE45S645

## VIVALDI